

Bosch ESI[truck] Heavy-duty diagnostics

Professional and expert software packages
with best coverage and more capabilities

The ESI[truck] platform features software package options for vehicles technicians see every day. The 3823 and 3824 software packages include all/makes model HD coverage, datastream and component actuations. Choose the 3824 package for even more – system info, technical info, parameter configurations, change calibrations, wiring diagrams, injector coding and service schedules.



BOSCH

Invented for life

3823 ESI[Truck] Pro-level software

For professional techs looking to do diesel particulate filter (DPF) regeneration, component actuation, special tests and automatic module identification for Class 6-8 trucks.

Best aftermarket coverage

- ▶ Truck brands: Freightliner, International, Kenworth, Mack, Volvo, Peterbilt, Sterling, Western Star
- ▶ Engine brands: Caterpillar, Detroit Diesel-MBE, Volvo, Mack, Navistar, PACCAR, Perkins, Deutz, MTU
- ▶ Brake systems
- ▶ Transmissions
- ▶ Trailer ABS
- ▶ In-depth heavy-duty and medium-duty
- ▶ Light-duty basic

Functions and efficiency technicians need

- ▶ Fault code report for entire truck
- ▶ Automatic vehicle ID
- ▶ Read and clear fault codes
- ▶ Cylinder cut-out
- ▶ Injector actuations
- ▶ Key component actuations
- ▶ Bluetooth wireless to VCI

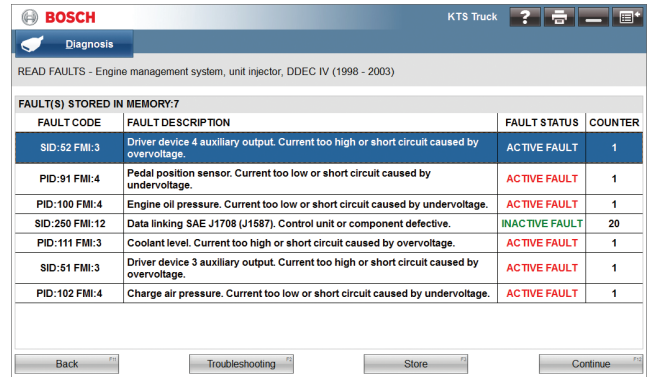

READ FAULTS - Engine management system, unit injector, DDEC IV (1998 - 2003)

FAULT CODE	FAULT DESCRIPTION	FAULT STATUS	COUNTER
SID:52 FMI:3	Driver device 4 auxiliary output. Current too high or short circuit caused by overvoltage.	ACTIVE FAULT	1
PID:91 FMI:4	Pedal position sensor. Current too low or short circuit caused by undervoltage.	ACTIVE FAULT	1
PID:100 FMI:4	Engine oil pressure. Current too low or short circuit caused by undervoltage.	ACTIVE FAULT	1
SID:250 FMI:12	Data linking SAE J1708 (J1587). Control unit or component defective.	INACTIVE FAULT	20
PID:111 FMI:3	Coolant level. Current too high or short circuit caused by overvoltage.	ACTIVE FAULT	1
SID:51 FMI:3	Driver device 3 auxiliary output. Current too high or short circuit caused by overvoltage.	ACTIVE FAULT	1
PID:102 FMI:4	Charge air pressure. Current too low or short circuit caused by undervoltage.	ACTIVE FAULT	1

Fault code

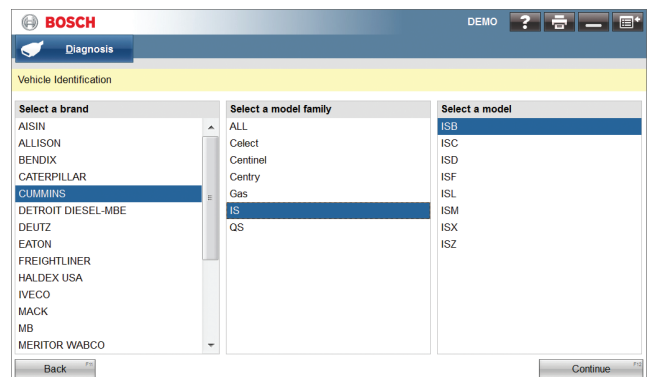

Vehicle Identification

Select a brand	Select a model family	Select a model
AISIN	ALL	ISB
ALLISON	Colect	ISC
BENDIX	Centinel	ISD
CATERPILLAR	Centry	ISF
CUMMINS	Gas	ISL
DETROIT DIESEL-MBE	IS	ISM
DEUTZ	QS	ISX
EATON		ISZ
FREIGHTLINER		
HALDEX USA		
IVECO		
MACK		
MB		
MERITOR WABCO		

Automatic vehicle ID

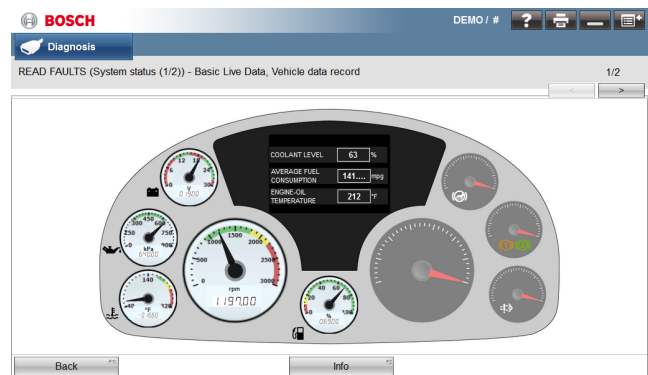

System status



3824 ESI[Truck] Expert-level software

For expert techs wanting all the functions of Pro level plus system info, technical info, parameter configurations, change calibrations, wiring diagrams, injector coding and service schedules.

All the ESI[truck] Pro-level features plus expert-level diagnostics:

- ▶ System tests (some automated)
- ▶ Leakage tests
- ▶ Injector coding and trim files
- ▶ Calibrations (including VGT)
- ▶ Adjustments and settings
- ▶ Wiring diagrams
- ▶ Technical data
 - Component locations
 - Installation specs
 - Component Specs
 - System operating specs

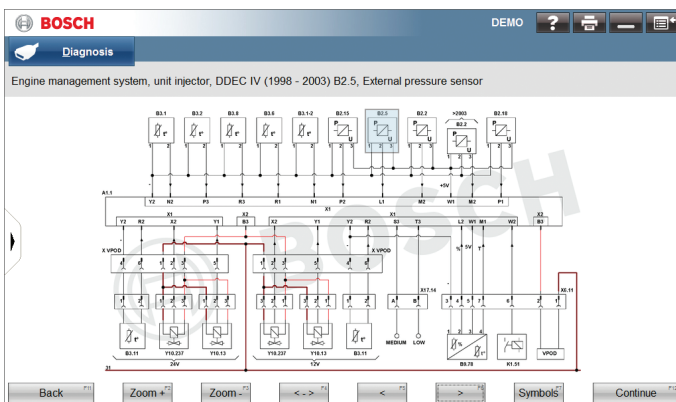

Wiring diagram

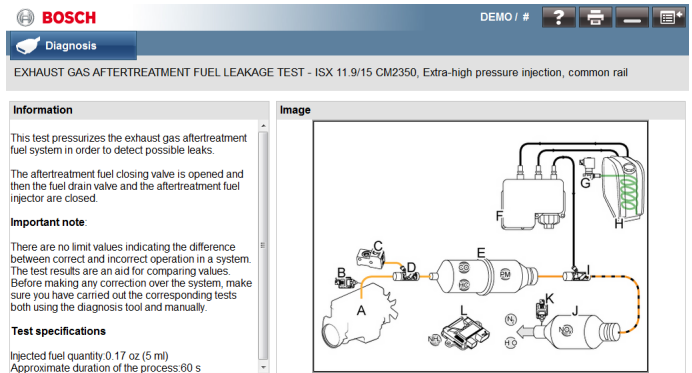

Leakage test

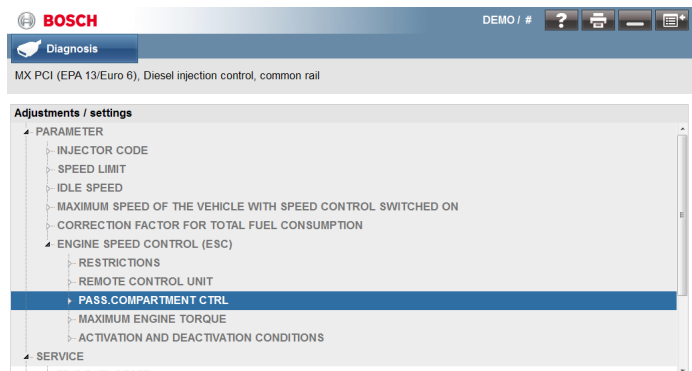

Adjustments & Settings

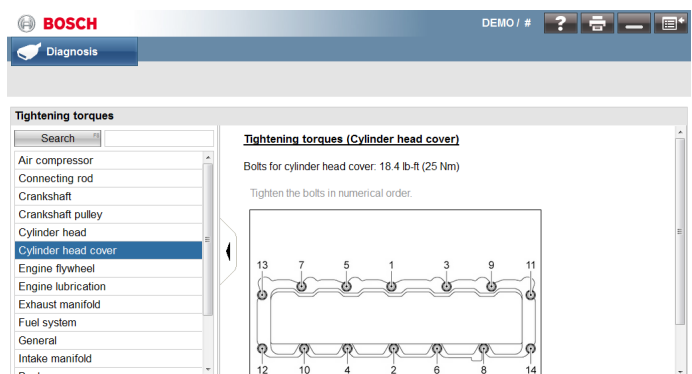

Technical data

Bosch ESI[Truck] Ordering Information

ESI[truck] Software Packages	Pro-level		Expert-level	
	3823BSC	3823	3824BSC	3824
10" tablet PC included	N/A	✓	N/A	✓
RP1210 communication interface	✓	✓	✓	✓
Create and print reports*	✓	✓	✓	✓
DPF regeneration and maintenance resets	✓	✓	✓	✓
Component actuations	✓	✓	✓	✓
Actuation tests	✓	✓	✓	✓
Data stream tables and graphing	✓	✓	✓	✓
Read and clear trouble codes	✓	✓	✓	✓
System tests (some automated)	N/A	N/A	✓	✓
Leakage tests	N/A	N/A	✓	✓
Injector coding and trim files	N/A	N/A	✓	✓
Calibrations (including VGT)	N/A	N/A	✓	✓
Adjustments and settings	N/A	N/A	✓	✓
Wiring diagrams	N/A	N/A	✓	✓
Technical data	N/A	N/A	✓	✓
One-year warranty	✓	✓	✓	✓
Troubleshooting subscription for faster diagnosis of engine, brake, transmission, ABS coverage and more	N/A	N/A	Optional	Optional

***HD Diagnostics coverage:** Freightliner, International, Kenworth, Mack, Volvo, Peterbilt, Sterling, Westernstar, MD Trucks, Isuzu, GM and Ford.

***Engine coverage:** Caterpillar, Cummins, Detroit Diesel-MBE, Deutz, MTU, Navistar, PACCAR, Perkins and Volvo, and includes medium- and light-duty software.

ADAPTERS

Bosch ESI[truck] Trailer Adapter 3824-06

7-pin PLC adapter for trailer ABS diagnostics

- ▶ J2497 Power Line Carrier (PLC) communication compatible
- ▶ Allows direct connection to trailer
- ▶ Works with tractor present or without the tractor present
 - External power supply is necessary without tractor
- ▶ Bosch ESI[truck] trailer ABS coverage for Bendix, Haldex, Meritor Wabco and Wabash systems
- ▶ Compatible with 3824, 3824BSC, 3823 and 3823BSC diagnostic tools



Bosch ESI[truck] 9 Pin Adapter Cable High Speed Comm 3824-10

- ▶ 9-pin heavy-duty diagnostic connector
- ▶ High-speed diagnostics communication
- ▶ Backward compatible with older black 9-pin vehicle connectors
- ▶ Compatible with 3824, 3824BSC, 3823 and 3823BSC diagnostic tools



LICENSE RENEWAL

Bosch ESI[truck] License Renewal 3823-08

- ▶ 12-Month Security Card includes one year of advanced diagnostic software for 3823, 3823BSC



Bosch ESI[truck] License Renewal 3824-08

- ▶ 12-Month Security Card includes one year of advanced diagnostic software for 3824, 3824BSC



SUBSCRIPTION

Bosch ESI[truck] Repair Information Subscription 3824-08R

- ▶ Fixes for +13,000 trouble codes
- ▶ Fixes for engine symptoms
- ▶ Can be added to 3824, 3824BSC, diagnostic tools



Extended service contracts available for all ESI[truck] software packages

One-, two- and three-year service contracts available.
Contact ToolGuard for more information at 1-800-233-7055

Learn more or request a demo at boschdiagnostics.com/pro.

17-55 Rev. C © 2017 Bosch Automotive Service Solutions Inc | 28635 Mound Road | Warren, MI 48092



BOSCH

Invented for life