

ADS 625X for ADAS Quick Start Guide



BOSCH

Bosch Technical Support: (855) 267-2483

Fax: 1-800-955-8329

techsupport.diagnostics@us.bosch.com

Please record and retain this important information:

Part No: _____

Serial No: _____

Purchase Date: _____

Safety Precautions

BEFORE OPERATING THIS TOOL, ALL OPERATORS SHOULD READ AND UNDERSTAND THIS QUICK START GUIDE AND FOLLOW ALL SAFETY WARNINGS AND INSTRUCTIONS.

KEEP THESE INSTRUCTIONS WITH THE TOOL FOR FUTURE REFERENCE. IF YOU HAVE ANY QUESTIONS, CONTACT YOUR BOSCH REPRESENTATIVE OR DISTRIBUTOR.

DANGER

When an engine is operating, keep the service area well ventilated or attach a building exhaust removal system to the engine exhaust system. Engines produce carbon monoxide, an odorless, poisonous gas that causes slower reaction time and can lead to death or serious personal injury.

WARNING:

- When working with hydraulic or fuel lines, be careful that liquids under pressure do not escape and create a dangerous condition. Use adequate ventilation and make sure there are no sparks or possibility of sparks that may ignite any vapor.
- Wear an American National Standards Institute (ANSI) Z87.1 approved eye shield when testing or repairing vehicles.
- Objects propelled by whirling engine components or pressurized liquids escaping may cause personal injury.
- Set the parking brake and block the wheels before testing or repairing a vehicle. It is especially important to block the wheels on front-wheel drive vehicles because the parking brake does not hold the drive wheels.
- Do not drive the vehicle and operate the software at the same time.
- Maintain adequate clearance around moving components or belts during testing.
- Moving components and belts can catch loose clothing, body parts, or test equipment and cause serious personal injury or tool damage.
- Automotive batteries contain sulfuric acid and produce explosive gases that can result in serious injury due to ignition of gases. Keep lit cigarettes, sparks, flames, and other ignition sources away from the battery at all times.
- Refer to the service manual for the vehicle being serviced. Adhere to all diagnostic procedures and precautions. Failure to do so could result in personal injury or otherwise unneeded repairs.
- Use only specially designed replacement parts (brake hoses and lines) for ABS equipped vehicles.
- After bleeding the brake system, check the brake pedal for excessive travel or a "spongy" feel. Bleed again if either condition is present.
- When installing transmitting devices (Citizen Band radio, telephone, etc) on ABS-equipped vehicles, do not locate the antenna near the ABS control unit or any other control unit.
- This equipment has been tested and found to comply with the limits for a Class B digital device, pursuant to Part 15 of the FCC Rules. These limits are designed to provide reasonable protection against harmful interference in a residential installation. This equipment generates and radiates radio frequency energy and, if not installed and used in accordance with the instructions, may cause harmful interference to radio communications.
- To reduce risk of injury, charge only Bosch Automotive Service Solutions, Inc. supplied charging block and power cord.
- Use of an attachment not recommended or sold by the battery charger manufacturer may result in fire, electric shock, or personal injury.
- Do not operate the tool with a damaged cord or connector. Replace damaged cords and connectors immediately.
- Do not operate the charger if it has received a sharp blow, been dropped, or otherwise damaged in any way. Take the charger to a qualified service person.
- Do not disassemble the charger. Take the charger to a qualified service person if service or repair is necessary. Incorrect reassembly may result in electric shock or fire. Unplug charger before attempting any maintenance or cleaning. Turning off controls will not reduce this risk.
- To prevent possible hearing damage, avoid using the tool at high volume levels for long periods.
- Do not expose tool or charger to rain, moisture, or snow.
- Verify that cords are located where they will not be stepped on, tripped over, or otherwise become a safety hazard or subjected to damage or stress.
- Use only batteries that are approved for use with this tool. Use of other types may increase the risk of fire or explosion.
- Do not carry a battery in your pocket, purse, or other container where metal objects (such as car keys or paper clips) could short-circuit the battery terminals. The resulting excessive current flow can cause extremely high temperatures and may result in damage to the battery pack or cause fire or burns.
- The battery poses a burn hazard if you handle it improperly. Do not disassemble it. Handle a damaged or leaking battery with extreme care. If the battery is damaged, electrolyte may leak from the cells and may cause personal injury.
- Keep the battery away from children.
- Do not store or leave your tool or battery near a heat source such as a radiator, fireplace, stove, electric heater, or other heat-generating appliance or otherwise expose it to temperatures in excess of 60°C (140°F). When heated to excessive temperatures, battery cells could explode or vent, causing personal injury or risk of fire.
- Do not dispose of your tool's battery in a fire or with normal household waste. Battery cells may explode. Discard a used battery according to the manufacturer's instructions or contact your local waste disposal agency for disposal instructions. Dispose of a spent or damaged battery promptly.

CAUTION:

- To avoid damage or generation of false data, make sure the vehicle battery is fully charged and the connection to the vehicle Data Link Connector (DLC) is clean and secure.
- Do not place the tool on the distributor of a vehicle. Strong electromagnetic interference can damage the tool.
- Never disconnect or reconnect any electrical connector while the ignition is on. Powertrain Control Module (PCM) damage may result.

General Information

Introduction

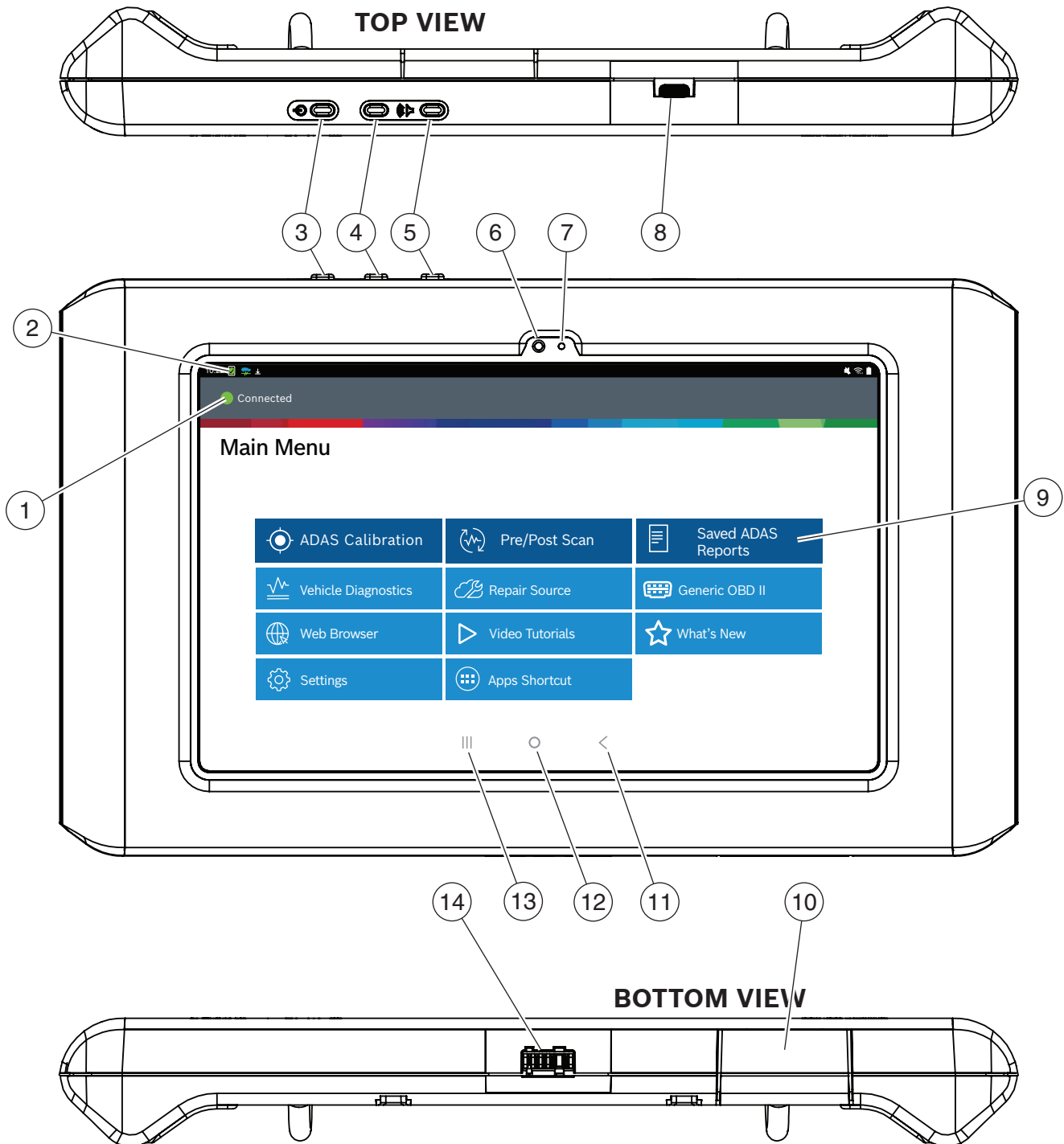

- | | | |
|---------------------------------|-----------------------------|-------------------------------|
| 1. Vehicle connection indicator | 5. Volume down button | 10. SD card access door |
| 2. VCI connection manager | 6. Front facing camera | 11. Back button |
| 3. Power button | 7. Ambient light sensor | 12. Home button |
| 4. Volume up button | 8. USB C charging/data port | 13. Recent app button |
| | 9. Main Menu functions | 14. Docking station connector |

Setup

1. Battery charging.

Connect the tablet to AC power using the USB power block and USB C charging cord and fully charge the battery.

When the tablet is turned on, the level of battery charge is indicated in the upper right corner of the screen.

Note: ADS 625X is supplied with 2 USB C power cables and 1 USB power block.

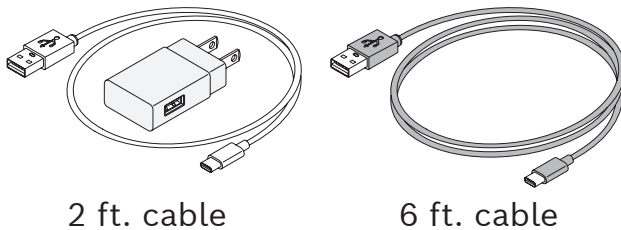

Battery Life Tips

The tablet is an Android based touch-screen tablet. The battery life icon shows charge level. The scan tool lets you know how much battery life is left by viewing the icon located at the top right of the home screen. Like all Android devices, there are tips to help extend or maximize battery life.

When not actively being used, the screen will timeout and the scan tool display will power off, while application remains running in background. The user can set the length of delay between the last screen touch and automatic screen timeout (dim and lock). From the Home screen, touch the Android App button - Settings - Display.

Select Screen timeout, then select the length of time from the last screen touch and automatic screen timeout.

To use again, press the power button to wake the tool up. This will allow maximum run time, while not limiting

productivity.

When the tool is powered up, even if it is not being actively used, Wi-Fi and Bluetooth® radios as well as all other necessary hardware are still being powered. Battery life is comparable to similar devices when in this state.

2. Docking station

The tablet, VCI, and cords should be stored in the docking station when not in use. The docking station powers the VCI and provides a slow, steady charge to the tablet to preserve battery integrity.

Seat the tablet and VCI in the docking station so that the docking station connector at the bottom of each device connects to the docking station.

The docking station includes two convenient USB ports to charge accessories and other devices.

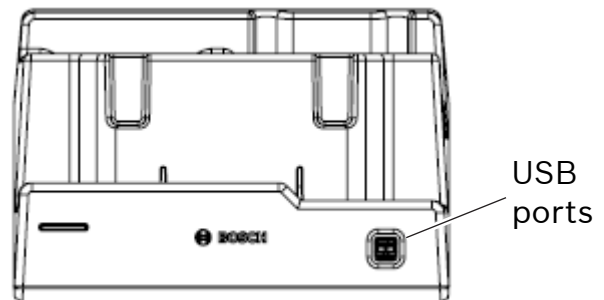

Notes:

- The docking station will not charge the tablet if the tablet's USB port is in use. Ensure no devices are connected to the USB port on the tablet before connecting to the docking station.
- For fastest charging, charge the tablet using the USB power block and USB C charging cord.

3. Press the power button to turn on the tablet.

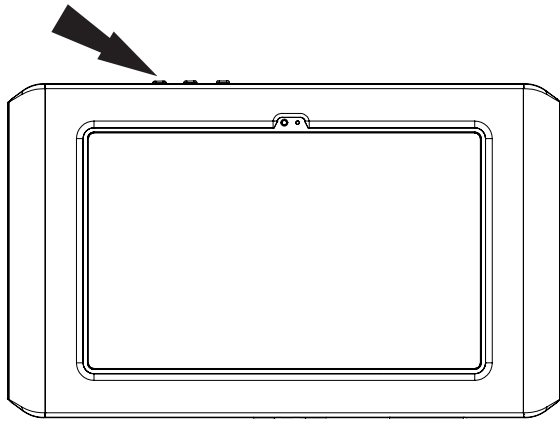

Power Button Functions

The power button has four functions

- ON: Press and hold the power button for about 5 seconds to turn the tablet on.
- OFF: Press and release the power button. A pop up window will appear to shut down the tablet. ON: If the screen times out or is in standby mode, press and release the power button to wake up the tablet. Turn ON: With tool off, press to turn ON
- OFF: Press the power button and hold for 5 seconds to turn the tablet off completely (not recommended).

4. Register Device - Select a Language

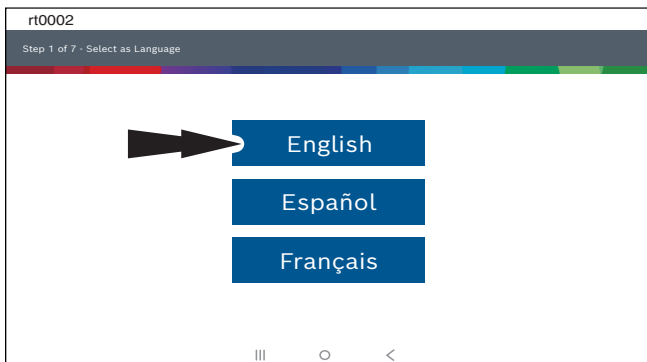

5. Select Register Now.

Register the tool, begin a trial period, or run the tool in demo mode.

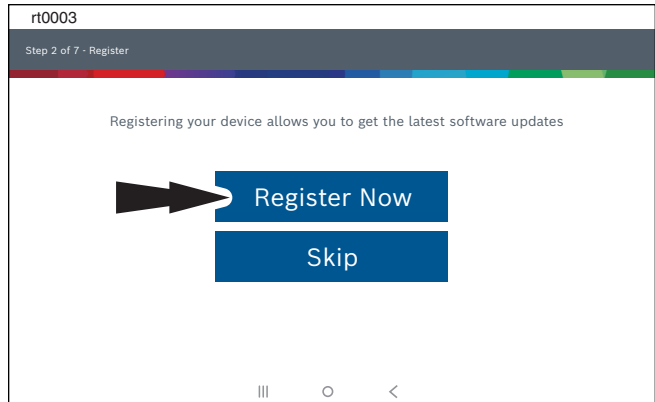

6. Read and accept the End User License Agreement.

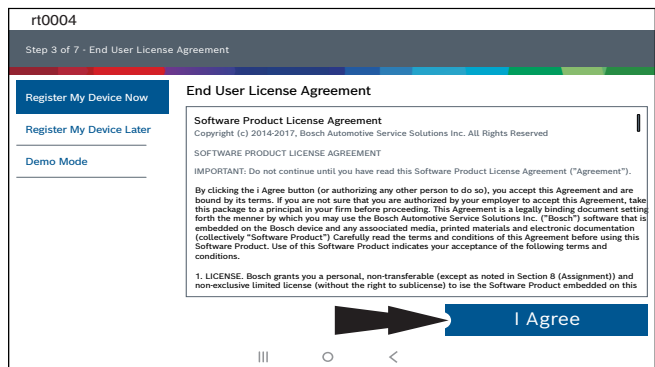

7. Select the correct Time Zone.

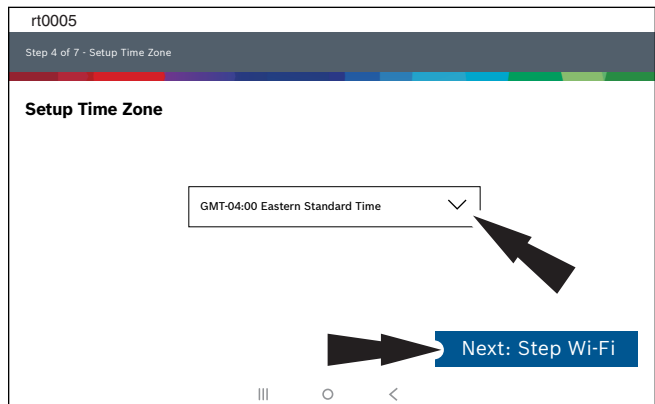

8. Enable Wi-Fi and select a network and select Next.

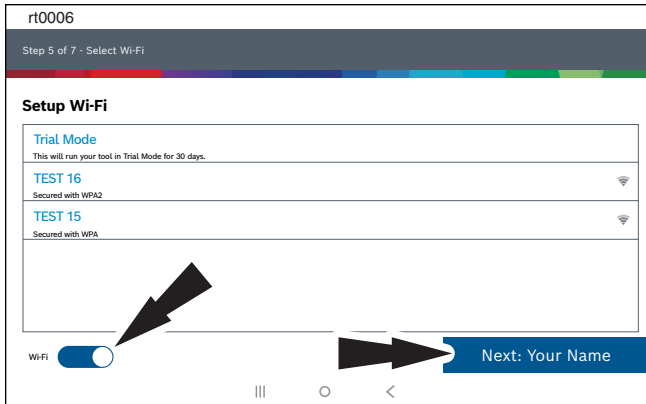

Note:

- Wi-Fi Must be ON. If Wi-Fi is OFF slide the Wi-Fi switch to the ON position and follow the prompts on the screen.
- If a Network password is required the Android Wi-Fi screen will be displayed. Follow the prompts on the screen.

9. Activate subscription and warranty

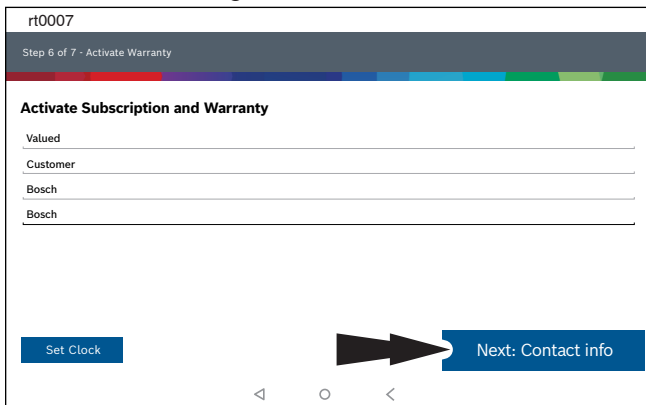

Enter your Name. Follow the prompts on the screen to activate warranty.

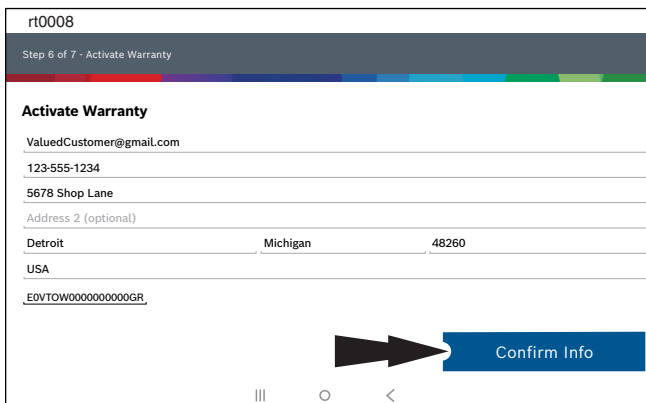

Enter contact information. Follow the

prompts on the screen.

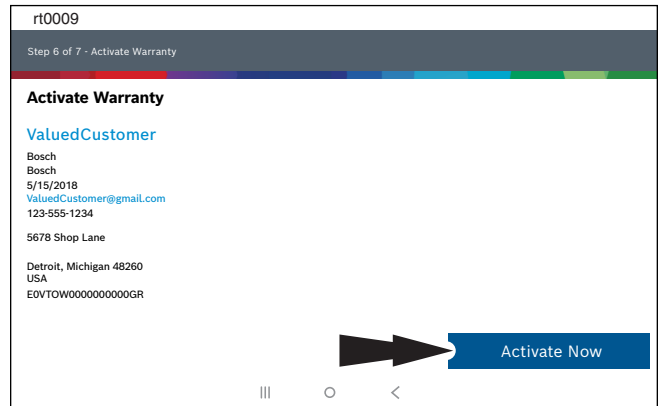

Confirm information. Follow the prompts on the screen and activate warranty.

10. Connect the VCI to the vehicle.

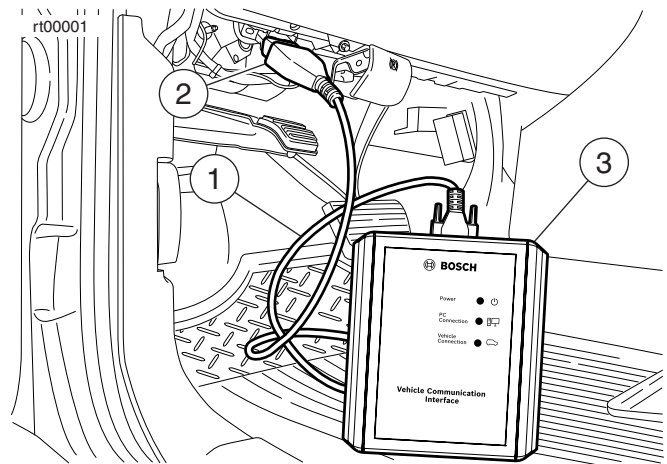

1. OBDII/DLC Cable
2. DLC
3. VCI

11. Connect the tablet to the VCI. Pairing

VCI Connection Manager Icon Definitions	
	Icon that will display when user is connected to DVCI.
	Icon will display when user is connected to DVCI but signal is degraded.
	Icon will display when user is NOT connected to DVCI.

VCI Connection Manager Icon Definitions



Icon will display when user is connected to DVCI, but the version does not match expected tablet version.

The VCI is paired to the tablet during manufacturing and should be paired out of the box.

- a. Connect the VCI to the vehicle DLC.
- b. At this point VCI Connection Manager icon should display “Connected via Wi-Fi”.
- c. If VCI Connection Manager icon shows “No connection,” select the VCI Connection Manager icon.

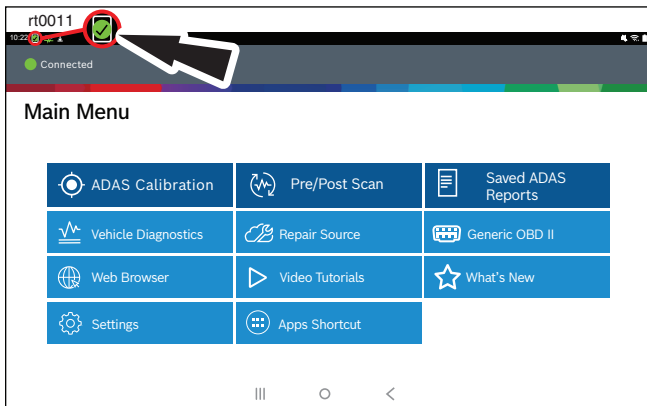

- d. Once VCI Connection Manager icon is selected, VCI Connection Manager dialog is displayed, listing discovered VCIs.
- e. Select “Connect” next to VCI in the list to pair with it.

Once VCI Connection Manager icon changes to “Connected via Wi-Fi”, the tool is ready to use.

The tablet is now paired to a VCI. To use a different VCI in the future, repeat the steps for manually pairing the VCI.

Select “Connect” next to desired VCI. VCI Connection Manager dialog will refresh to show successful connection.

ss02876

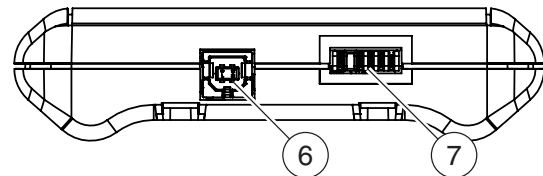
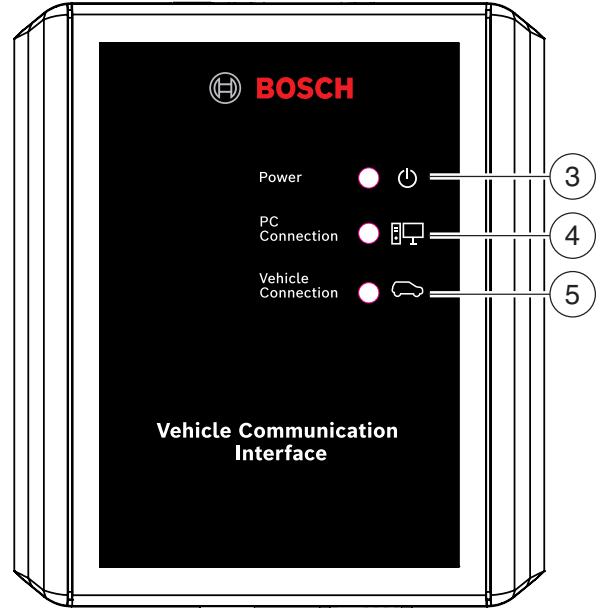
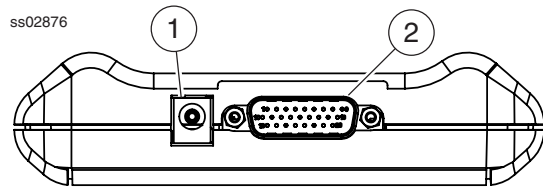

1. **Power port (used when necessary)**
2. **DLC/OBDII cable port**
3. **Power**
Indicates the VCI has received power.
4. **PC Connection**
Indicates the VCI is communicating with the PC.
5. **Vehicle Connection**
Indicates the VCI is communicating with vehicle.
6. **USB “B” Port.**
7. **Docking station connector.**

Main Menu

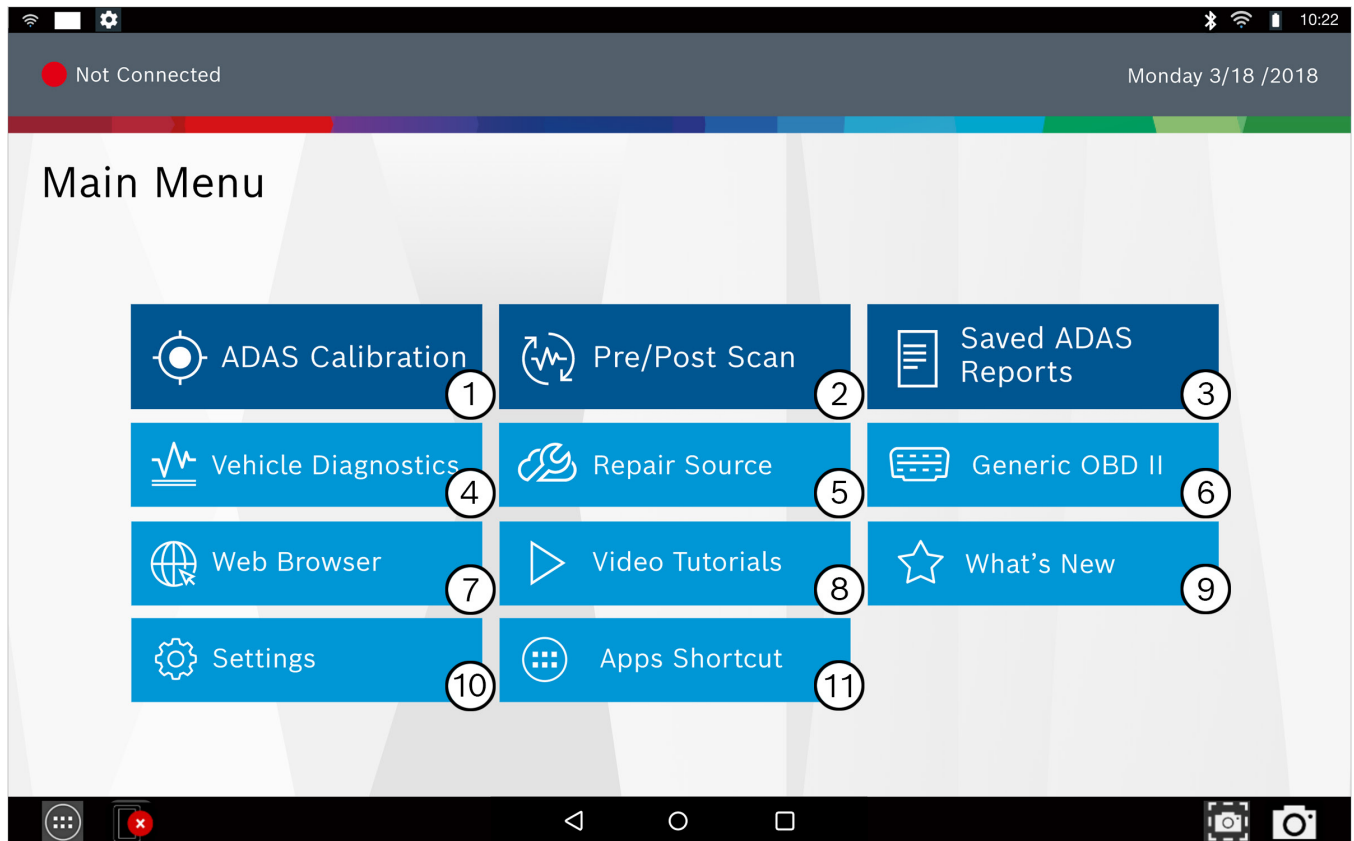

1. **ADAS Calibration**
Access ADAS calibration options
2. **Pre/Post Scan**
Access pre/post scan function
3. **Saved ADAS Reports**
Access saved ADAS reports
4. **Vehicle Diagnostics**
Access vehicle diagnostic options
5. **Repair Source**
Access online automotive diagnostic repair information
6. **Generic OBD II**
Access global OBDII emission-related ECU information
7. **Web Browser**
Full internet access and shortcuts to repair information and OEM websites
8. **Video Tutorials**
Access video tutorials
9. **What's New**
Preview scan tool features and operation
10. **Settings**
Access tool settings, printer setup, subscription information, software updates, and more
11. **Apps Shortcut**
Access other available Android applications

ADAS Calibration Functions

After selecting a vehicle the user will be able to begin using ADAS calibration functions on the vehicle.

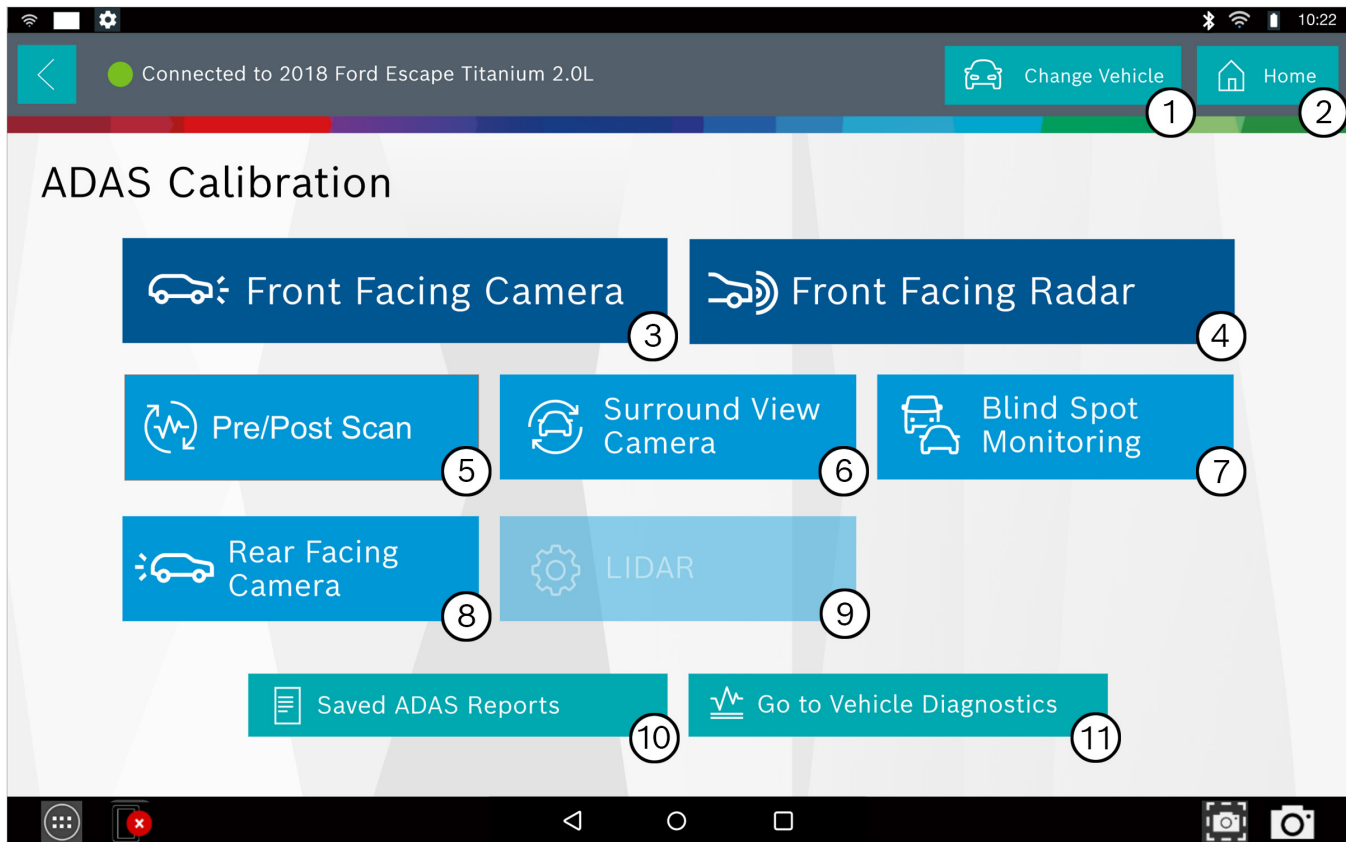

1. Change Vehicle

Shortcut to select a new vehicle (Choose this only to select a new vehicle.)

2. Home

Shortcut to the Main Menu

3. Front Facing Camera

Access to systems for the front facing camera calibration

4. Front Facing Radar

Access to the systems for the front facing radar calibration

5. Pre-Post Scan

Access pre/post scan function

6. Surround View Camera

Access to the systems for surround view camera calibration

7. Blind Spot Monitoring

Access to the systems for blind spot monitor calibration

8. Rear Facing Camera

Access to the systems for rear facing (back-up) camera calibration

9. LIDAR

Access to the systems for LIDAR calibration

10. Saved ADAS Reports

Access saved ADAS reports

11. Go to Vehicle Diagnostics

Access diagnostic functions screen

Guided Tour

The guided tour is a step-by-step work instruction, specific to the selected vehicle, to easily guide the user through all of the steps to set up and recalibrate a vehicle's ADAS systems.

< ●
Change Vehicle
Home

Static Camera Aiming

Screen Capture

Guided Tour Summary:

1. Positioning Distance Marker Stand
2. Attaching Wheel Clamps & Alignment Markers
3. Computer Vision Positioning
4. Setting Target Board Pitch
5. Adjust Target Height
6. Leveling Crossbar
7. Install Target Boards

Back

Exit

Continue

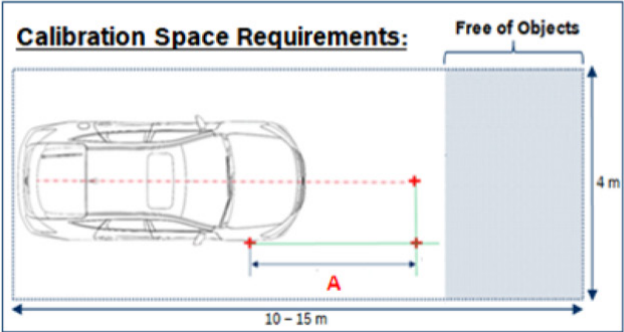

Calibration Space Requirements: The diagram shows a car on the left and a target board on the right. The distance between the car and the target board is labeled 'A'. The total distance from the car to the target board is labeled '10 - 15 m'. The height of the target board is labeled '4 m'. The area to the right of the target board is labeled 'Free of Objects'.

(Image for reference only. The guided tour is customized for each year/make/model based on vehicle selection.)

The guided tour includes Bosch's innovative ADAS computer vision positioning system to aid in accurate and speedy setup and recalibration of a vehicle's ADAS systems.

ADAS Computer Vision Positioning Screen

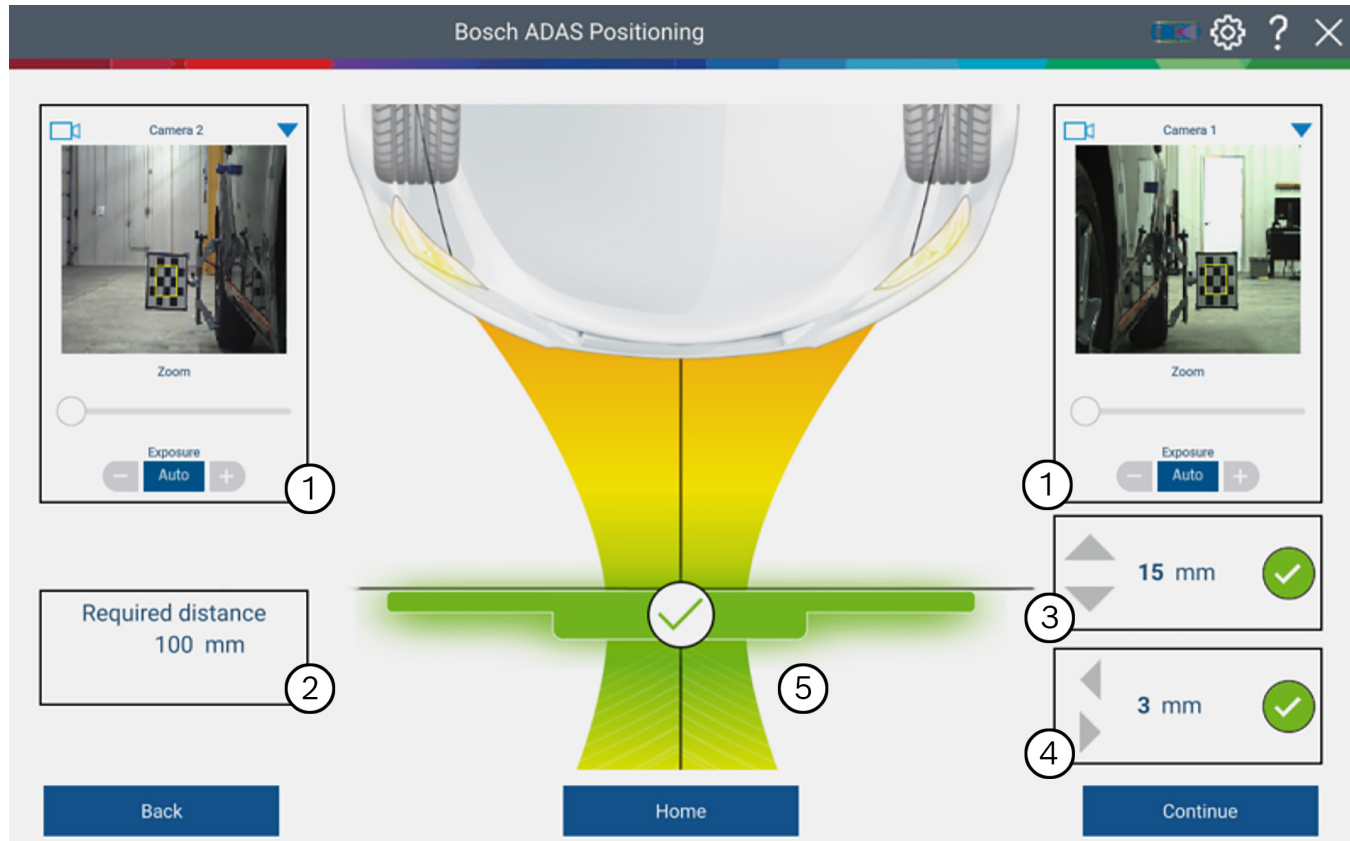

The guided tour also includes Bosch's innovative ADAS computer vision positioning system to aid in accurate and speedy setup and calibration of a vehicle's ADAS systems. Your screen may look slightly different based on selections and process. When out of tolerance, the green checkmark icons are replaced with red icons.

1. Wheel Clamp Targets

Left and right wheel clamp targets camera view, including camera controls for exposure and zoom

2. Required Set-up Distance

The required set-up distance of the ADAS recalibration fixture to the vehicle is a static value, dependent on vehicle and ADAS system selection

3. Forward/Backward Position

The dynamic (forward/backward) position value of the ADAS recalibration fixture relative to the vehicle

4. Left/Right Position

The dynamic (left/right) position value of the ADAS recalibration fixture relative to the vehicle

5. Angular Position

The dynamic (clockwise/counterclockwise) angular position value of the ADAS recalibration fixture relative to the vehicle (This screen shows the setting within tolerance. Your screen will vary. When out of tolerance a crosshair and dynamic value is shown.)

Diagnostic Functions

After selecting a vehicle the user will be able to begin using diagnostic functions on the vehicle.

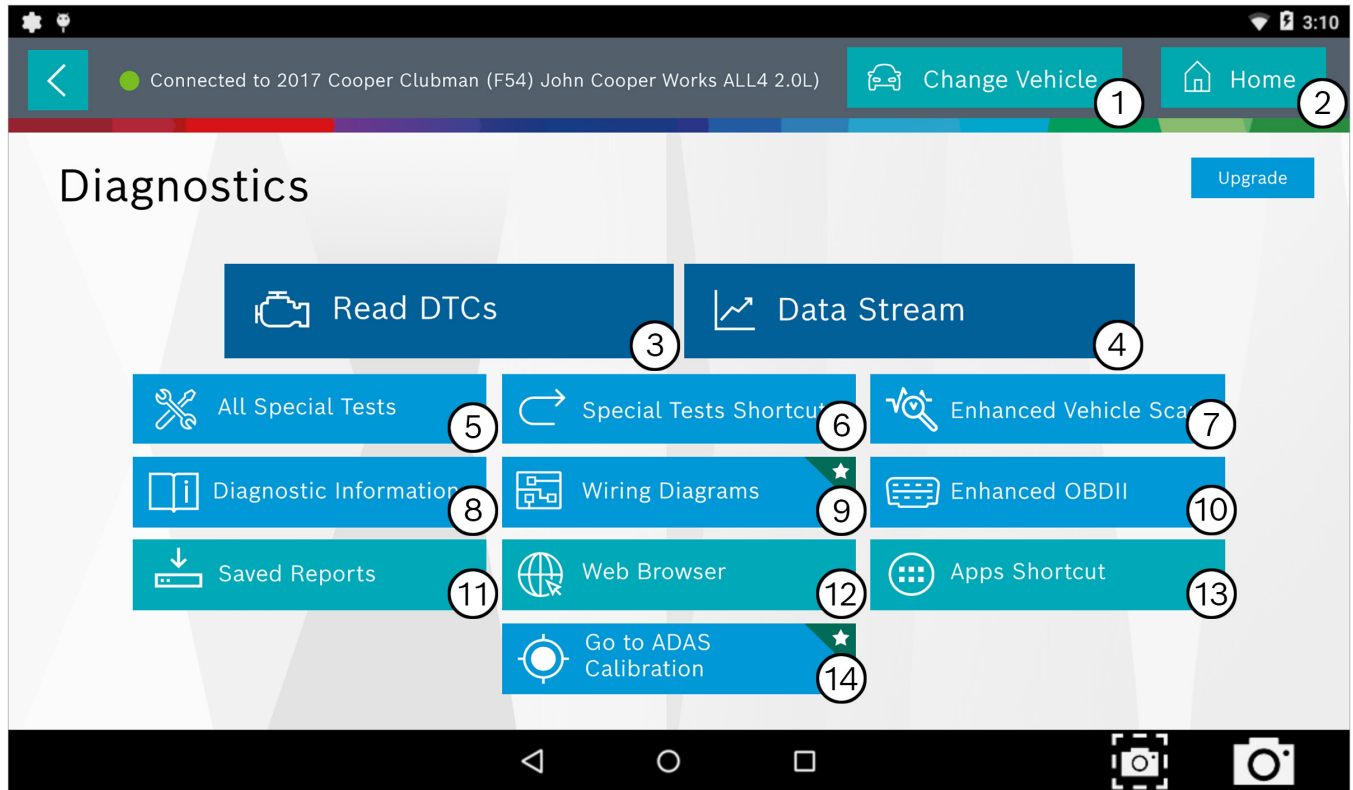

1. Change Vehicle

Shortcut to the select vehicle screen

2. Home

Shortcut to the Main Menu

3. Read DTCs

Read all DTCs on selected vehicle

4. Data Stream

The data stream function shows live sensor and solenoid data streaming from the vehicle ECU (electronic control unit)

5. All Special Tests

Access to bi-directional tests, relearns, adjustments, calibrations, and all other special tests

6. Special Tests Shortcuts

Access frequently used special maintenance tests for specific systems to be recalibrated or reset after service, including ADAS recalibration

7. Enhanced Vehicle Scan

Access manufacturer-specific parameters and information

8. Diagnostic Information

Diagnostic Information provides diagnostic, repair, and reset information for the selected vehicle

9. Wiring Diagrams

Access vehicle system wiring diagrams (Wiring diagrams subscription required)

10. Enhanced OBDII

Access manufacturer-specific parameters and information.

11. Saved Reports

Locate saved vehicle reports

12. Web Browser

Full internet access and shortcuts to repair information and OEM websites

13. Apps Shortcut

Access other available Android applications

14. Go to ADAS Calibration

Access ADAS calibration functions screen (ADAS subscription required)

Features

OBDII/DLC Cable

The OBDII/DLC cable has a LED lamp to locate vehicle DLC and voltmeter that displays battery voltage

- The LED in the OBDII cable end is activated by a button on the side of the connector. This feature is provided to assist users in finding the vehicle DLC.
- The vehicle battery indicator is activated when the OBDII cable is plugged into the vehicle and displays the Pin 16 voltage available on the vehicle DLC. A voltage reading below 11.8 Volts will activate an indication of “LO” or if above 15.5 Volts and indication of “HI” will activate highlighting that the battery or charging system needs attention.

ss02659

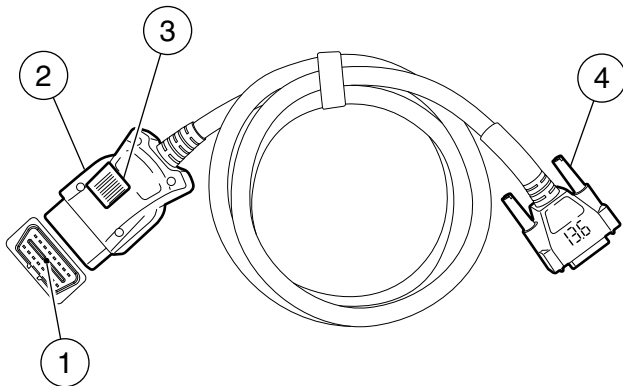

1. LED Lamp
2. LED lamp switch
3. Battery cover
4. DLC tool connector with voltmeter

Software Updates

Software Updates: Periodically, updates will become available and the user will be notified through a message on the screen. To receive updates automatically, connect to Wi-Fi and leave scan tool on overnight.

Note: Scan Tool will download updates automatically when connected to the internet. When download is complete, the user will be informed with a pop up screen. To install an update, the scan tool must be connected to the AC power adapter, over 50% battery life and not connected to a vehicles DLC.

AutoDetect®

The new user interface utilizes graphic “badges” to illustrate when critical information is found. AutoDetect® automatically detects vehicle-specific solutions and graphically alerts the user of on-tool or web-based repair information found. To use the Code To Fix® feature, press the Diagnostic Trouble Code to launch the DTC Info screen for access to exclusive experienced-based fixes and repair information for that specific vehicle and DTC.

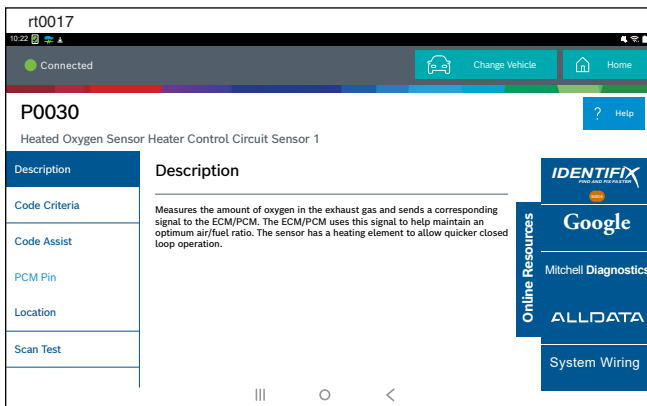
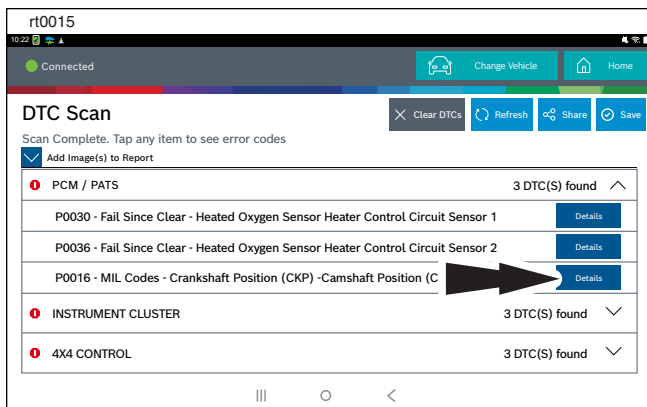

How to Power Off ADS 625X

- a. Press and release the power button.



- b. Select Power Off. The tool will now shutdown.

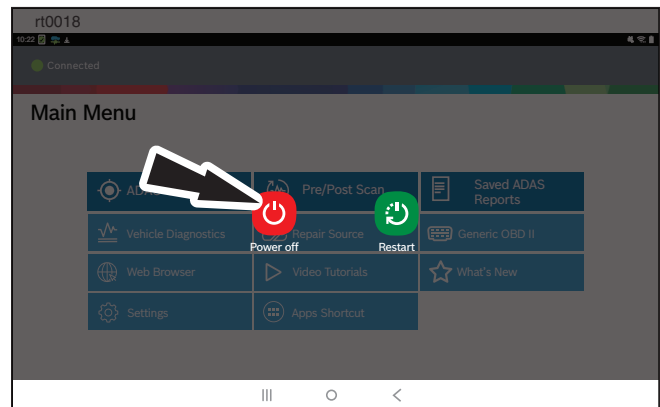

Note: When switching vehicles, it is best to return to the home screen before disconnecting the VCI from the vehicle to avoid communication errors.



Bosch

Automotive Service Solutions, Inc.

655 Eisenhower Drive
Owatonna, MN 55060 USA
Phone: 1-855-267-2483 Option 1

www.boschdiagnostics.com

1699504264 VER 01

